

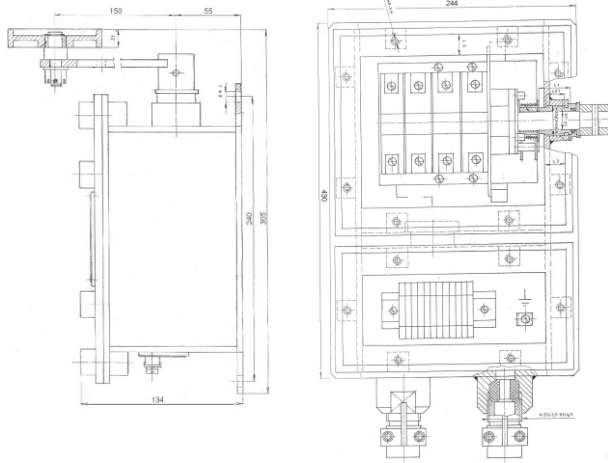

SXD-01 limit switch lever

Certificate: ATEX



Specifications of SXD-01

Design	IM2 Ex d I Mb
Voltage	L+PE+N, 230VAC/50Hz
Cross-section of connected wires	1.5 to 6 mm ²
Temperature range	-20°C to +40°C
Relative humidity (max.)	95% w/o condensation
Case	IP54
Dimensions	430 x 244 x 134 mm
Weight	9.5 kg
Weight of electrical equipment	2 kg

Description of switching:

- The lever goes back alone to 0° after shifting between 0° and 90°.
- The last handling of the lever was, e.g. to position I. Contacts K1 and K2 are closed.
- On moving the lever back into position I, the position of the contacts does not change.
- Moving the lever from position II to position III with a shift of about 50° to 55° results in contacts K1 and K2 opening, K3 and K4 closing. The lever goes back alone from position III to position II.
- On moving the lever back from position II to position III, the status of the contacts does not change.
- Moving the lever from position II to position I with a shift of about 50° to 55° results in contacts K1 and K2 closing, K3 and K4 opening. The lever goes back alone from position I to position II.

Application:

The SXD-01 explosion-proof limit switch can be used for switching electrical circuits on and off, for signaling the end positions of elevators and hoisting machinery, for controlling pumps to regulate level and controlling pumps and compressors to maintain the desired pressure in the piping and for controlling other power equipment.

No other non-intrinsically safe voltage may be present in the housing when used for switching intrinsically safe signals.

Description:

The SXD-01 explosion-proof limit switch is designed as a solid enclosure – it consists of a welded sheet metal cabinet with a topcoat made from powdered paint. The cables are connected through the terminal compartment to the instrument compartment using two non-explosive PNV32 bushings. A two-position lever-operated switch extending out from the right side of the cabinet is located inside the cabinet. The lever is adapted for manual operation and additional devices can be attached after further modification (e.g., chain control). The standard length of the lever is 150 mm with an 80 mm wheel at the end.

The status of the contacts is maintained; switching the contacts occurs when the lever is shifted by 50° to 55° to the opposite side.

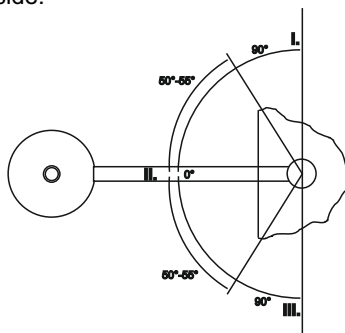

Shift of the control lever

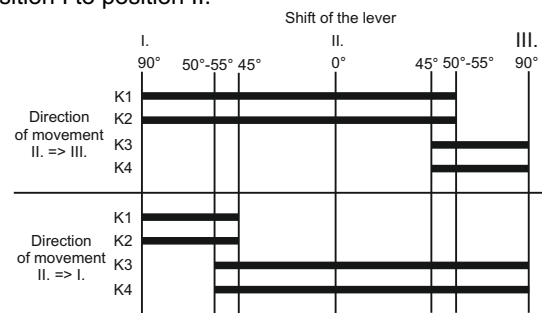

Graph of switching contacts

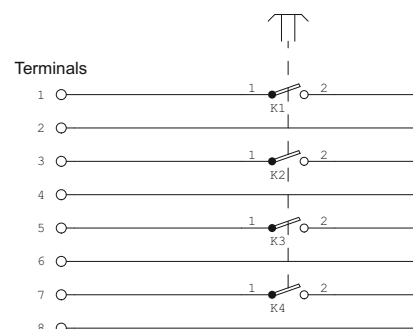

Schematic of connections

The catalogue has only those selected important parameters for your final decision. For project designs always ask for the user's guide for this product and any engineering consultation about possible uses.